

WASCO

SWITCHES & SENSORS

P110 PRESSURE SWITCH SERIES

Industry leading customers have depended upon the reliable performance of the P110 Series since 1987. This series features a stainless steel body and a dual seal construction. The P110 Series incorporates Wasco's proprietary manufacturing method that we have perfected over the last three decades.

This series is a rugged pressure switch that is perfect for industrial systems that require cost-effective reliability.



P110 SERIES HIGHLIGHTS

We've designed the P110 series for high performance and dependability. All P110 Series switches are leak tested to $\leq 1 \times 10^{-3}$ std cc/min Air.

TYPICAL APPLICATIONS

- Gas Systems
- Air Filtration
- Medical
- HVAC-R
- Aerospace
- Food Processing
- Transportation Equipment

P110 SERIES PERFORMANCE CHART

Sensor	Max. System Pressure* (PSIG)	Set Point Range* (PSIG)	Set Point Tolerance (PSI)	Typical Reset Band (PSI)
3	30.0	1.0 - 30.0	± 0.7	0.7 - 2.3
5	125.0	3.0 - 125.0	± 2.0	1.3 - 3.8
8	250.0	8.0 - 250.0	± 5.0	2.0 - 10.0

* Other ranges available

MATERIAL SPECS

	Wetted Components
Fitting	300 Series SS
Sensor	17-7PH SS
O-Ring	Buna, Viton, or EPR

TECHNICAL SPECS

Life Cycle	≥1,000,000 cycles
Ingress Protection	IP65
Leak Rate	100% Tested to ≤ 1 x 10 ⁻³ std cc/min
Operating Temp	-65° to 225°F -54° to 107°C

P110 DIMENSIONS

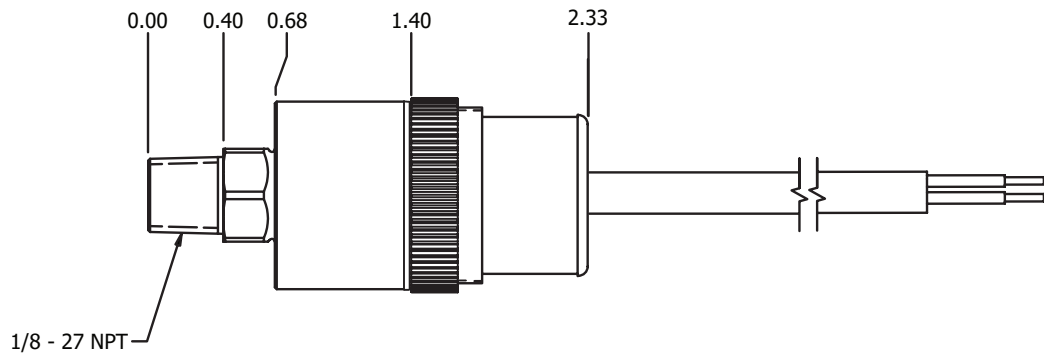

Typical P110 with 1/8-27 NPT and jacketed wire leads (other configurations available)

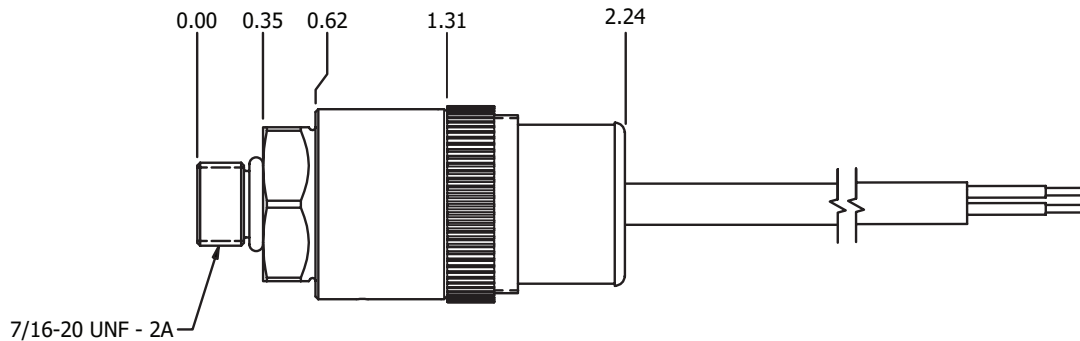

Typical P110 with 7/16-20 UNF and jacketed wire leads (other configurations available)

We understand how difficult the specifying process is, but we believe it shouldn't be so confusing. Wasco has specified over 6000 unique pressure sensors for thousands of customers since 1963.

Find your solution today by filling out our [worksheet](#).

*Information contained in this document is for reference only. Actual product specifications will be provided on an engineering drawing. Released November, 2021



SCAN ME